



IONPURE® VNX55-E HIGH FLOW CONTINUOUS ELECTRODEIONIZATION (CEDI) MODULES

IONPURE® VNX MODULE VNX55E-2

The VNX55-E high flow module is designed with proven Ionpure® continuous electrodeionization (CEDI) technology to produce high purity water. Performance has been optimized for high recovery and the ultrapure water demands of the microelectronics industry.

Each VNX55-E industrial module has a nominal flow rate of 55 gpm (12.5 m³/hr). Multiple 55 gpm modules provide for simplified system design with flow rates up to, and greater than 1,000 gpm.

VNX55-E SERIES FEATURES

- Guaranteed 18 MΩ-cm product resistivity, optimized for microelectronics and UPW systems
- Silica and Boron removal of \bar{G} 95%
- Sodium and chloride removal \bar{G} 99.8%
- 98.5-99% recovery for loop usage and high water savings
- No need for acid/caustic, neutralization systems or tank exchanges
- Significantly lowers operating costs compared to conventional ion exchange
- Robust leak-free sealing with through-port gasket
- High flow module reduces system costs and simplifies skid design
- Connection fittings are included
- On-board junction box for DC power connections
- 50mm butt weld natural polypropylene kits and drawings available

For additional information on our VNX Series call +1 866.876.3340 or visit our website at www.ionpure.com.

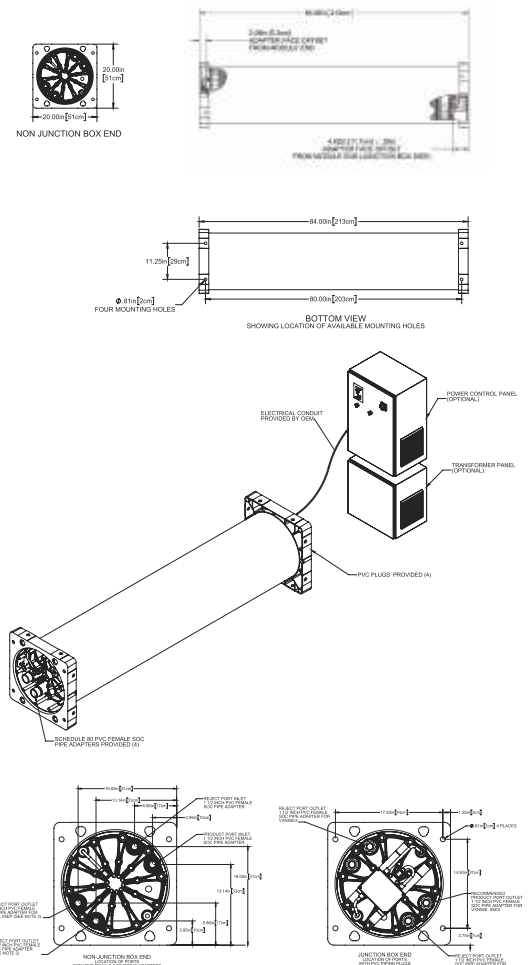

OPERATING ENVIRONMENT

Installation should be indoors with no direct sunlight and should have a maximum ambient temperature of 113°F (45°C).

MATERIAL CONSTRUCTION

1. Wetted components of the VNX module consist of: PVC (adapters), nylon/ABS, polypropylene, silicone rubber, ion-selective membranes, ion exchange resins and thermoplastic elastomer.
2. Housing is fiberglass reinforced plastic (FRP). Standard color is white with a glossy finish. Custom colors and labeling are available.
3. The proprietary Flexmount bracket/end-block assembly is an epoxy painted aluminum casting suitable for securing modules to the frame and/or each other in Ionpure® approved configurations.

QUALITY ASSURANCE STANDARDS

CE marked. Each module is factory tested to meet strict industry standards and is manufactured in an ISO 9001 and ISO 14000 quality and environmental management system.

ORDERING INFORMATION

1. Use model number IP-VNX55E-2 (W3T306193) when ordering for vertical or horizontal installation.
2. Each VNX module has four process connections; feed, concentrate feed, product and reject. PVC adapters (with dust covers) and plugs are provided with the module. High purity 50 mm polypropylene adapters are also available.
3. High purity 50mm butt weld connection kits adapter (4)/plug (4):
Natural polypropylene Model #IP-VNX-CK-PP-2
4. Standard 1.5 female socket connection kits (4)/plug (4):
PVC Model #IP-VNX-CK-PVC-2.
5. Module electrical power connections are made through an on-board junction box.

PHYSICAL SPECIFICATIONS

Diameter	Width	Height	Length	Shipping Weight	Operating Weight
17.5 (44.45 cm)	20.0 (50.8 cm)	20.0 (50.8 cm)	84.0 (213.3 cm)	610 lbs (276.7 kg)	825 lbs (374.2 kg)

MAXIMUM FEED WATER SPECIFICATIONS

Feed water conductivity equivalent, including CO ₂ and Silica	< 10 DS/cm
Feed water source	RO permeate (2 pass) or DI water
Temperature	68 113°F (20 45°C)
Inlet pressure	20 100 psi (1.4 7 bar)
Maximum total chlorine (as Cl ₂)	< 0.02 ppm
Iron (Fe)	< 0.01 ppm
Manganese (Mn)	< 0.01 ppm
Sulfide (H ₂ S)	< 0.01 ppm
pH	4 11
Total hardness (as CaCO ₃)	< 0.1 ppm
Dissolved organics (TOC as C)	< 0.5 ppm
Silica (SiO ₂)	< 0.2 ppm

TYPICAL MODULE PERFORMANCE

OPERATING PARAMETERS

Recovery	98.5 99%
Flow rate: minimum	33 gpm (7.5m ³ /hr)
Flow rate: nominal	55 gpm (12.5 m ³ /hr)
Flow rate: maximum	73.5 gpm (16.7 m ³ /hr)
DC voltage	0 300
DC amperage	1.0 - 13.2**

PRODUCT WATER QUALITY

Product resistivity 2-pass RO Permeate	> 17.5 megohm-cm*
Product resistivity DI water	> 18 megohm-cm*
Silica (SiO ₂) removal	≥ 95%
Boron (B) removal	≥ 95%
Sodium (Na) removal	99.8%
Chloride (Cl) removal	99.8%

*Actual performance may be determined using the IP-Pro projection software available from Ionpure®

**0-10 amp typical for most applications.



Geofluid Processors Private Limited

112, Building No.2, Mittal Industrial Estate,
Andheri Kurla Road, Marol, Andheri (E), Mumbai - 400 059.

+91-22- 6155 5888

info@geofluid.com

+91-22-6155 5800

www.geofluid.com