

SELF-CLEANING DISC FILTRATION EQUIPMENT

Working conditions

Salinity	6000 – 55000 mg/l
Max. working pressure	10 bar (145 psi)
Min. working pressure	0.8 bar (11.6 psi)
Min. backwash pressure	1.5 bar (22 psi)
Min. backwash flow	5 l/s (79 gpm) per filter 4"
Backwash duration	20 – 30 s per filter 4"
pH	4 - 11
Water temperature	≤ 60 °C (140 °F)

Filtration degrees (micron)

400	200	130	100	50	20	10	5
-----	-----	-----	-----	----	----	----	---

DLP Technology
Low Pressure Backflush



DESCRIPTION

Self-cleaning disc filtration equipment composed by 3 to 12 filters AZUD HELIX AUTOMATIC Ø4" with discs AZUD MG/WS, which perform an in-depth 3D filtration, installed in-line on Ø6"-Ø12" inlet/outlet manifolds. Includes Ø3" backwash valves 3-way membrane type and the innovative DLP TECHNOLOGY, that enable the sequential low-pressure backwashing of each filter using filtered water from the rest of filters of the equipment, while continues the filtered water supply downstream. The patented AZUD HELIX anti-clogging deflector provides a reliable filtration thanks to an effect of centrifugal separation, with less backwash frequency and less water and energy consumption. The materials of construction of these equipment are specifically designed to optimize the filtration in installations with high salinity water.

Smart, compact and modular plug&play solution, increases the shelf life of the installation providing a long-term operation with minimum operational costs and less maintenance downtime.

APPLICATIONS



> Filtration in tanks, lakes and fountains



> Ultrafiltration membrane protection



> Make-up water filtration



> Media filters prefiltration

HOW DO THEY WORK

FILTRATION PHASE:

- Water flows from the Inlet manifold to the Inside of the filter, passing through the anti-clogging deflector AZUD HELIX, which throws the heavy particles away from the disc stack, avoiding the quick clogging of the filter and minimizing the backwash frequency.
- Water flows OUT-IN through the disc stack to the outlet manifold while particles bigger than the filtration degree are trapped in the discs.

SELF-CLEANING PHASE:

- When automatic backwash is activated, the pressurized water flows IN-OUT, decompressing the disc stack.
- High-speed flushing water flowing through the spray nozzles, creates a tangential cleaning effect the flush out the trapped particles.

▶ Check our YouTube channel for more details

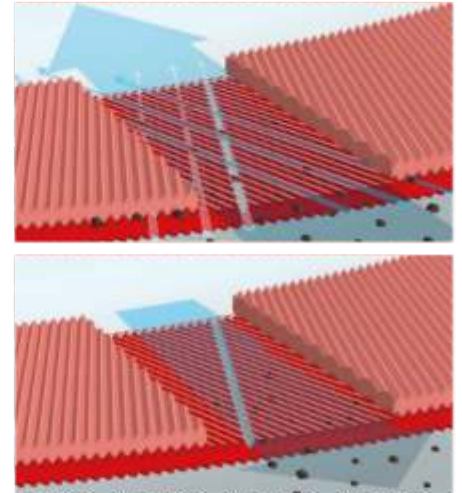

MODELS

Filtration area	Model	Q max. 50 µm* m³/h (gpm)	Q max. 130 µm* m³/h (gpm)	Connection	INLET AND OUTLET MANIFOLD		AZUD FBC control unit**
					DIN 2576	ANSI B16.5 CLASS 150	
9720 cm²	FT4DCL3 SW 3 filters Ø4"	84 (370)	156 (687)	Ø6"	•	•	103/3 SW
12960 cm²	FT4DCL4 SW 4 filters Ø4"	112 (493)	160 (705) 208 (916)	Ø6" Ø8"	•	•	112/4 SW
16200 cm²	FT4DCL5 SW 5 filters Ø4"	140 (616)	160 (705) 240 (1057)	Ø6" Ø8"	•	•	112/5 SW
19440 cm²	FT4DCL6 SW 6 filters Ø4"	168 (740)	240 (1057) 312 (1374)	Ø8" Ø10"	•	•	112/6 SW
22680 cm²	FT4DCL7 SW 7 filters Ø4"	196 (863)	240 (1057) 364 (1603)	Ø8" Ø10"	•	•	112/7 SW
25920 cm²	FT4DCL8 SW 8 filters Ø4"	224 (986)	240 (1057) 380 (1673)	Ø8" Ø10"	•	•	112/8 SW
29160 cm²	FT4DCL9 SW 9 filters Ø4"	252 (1110)	380 (1673) 468 (2061)	Ø10" Ø12"	•	•	112/9 SW
32400 cm²	FT4DCL10 SW 10 filters Ø4"	280 (1233)	380 (1673) 520 (2290)	Ø10" Ø12"	•	•	112/10 SW
35640 cm²	FT4DCL11 SW 11 filters Ø4"	308 (1356)	380 (1673) 572 (2519)	Ø10" Ø12"	•	•	112/11 SW
38880 cm²	FT4DCL12 SW 12 filters Ø4"	336 (1480)	380 (1673) 624 (2748)	Ø10" Ø12"	•	•	112/12 SW

DRAINAGE MANIFOLD: Ø4" Grooved/PVC

*Maximum flowrate is limited by the size and type of the auxiliary elements (manifold, flanges and valves).

**AZUD FBC control unit not included with the equipment.

MATERIALS OF CONSTRUCTION

Filters	Backwash valves Inlet/outlet/drainage manifolds	Scheme
<p>Ø4" Filters (3-12 units)</p> <ul style="list-style-type: none"> • MG/WS discs: PP/HDPE • Support structure: rPP • Base-lid: rPA • Spring: HASTELLOY • Clamp: SS 316L • Sealing o-rings: NBR/HDPE 	<p>Ø3" Valves 3 way-membrane (1 unit / filter)</p> <ul style="list-style-type: none"> • Body: rPA • Axis, seat and spring: SS DUPLEX • Sealing o-rings: NBR • Command: Pneumatic (PN) <p>Manifolds: HDPE PE-100 Flanges: PP coated steel</p>	

PP: Polypropylene rPP: Reinforced polypropylene SS: Stainless steel rPA: Reinforced polyamide HDPE: High density polyethylene NBR: Nitrile rubber

MICRON 100 130 200 400

FT4DCL3 SW DLP

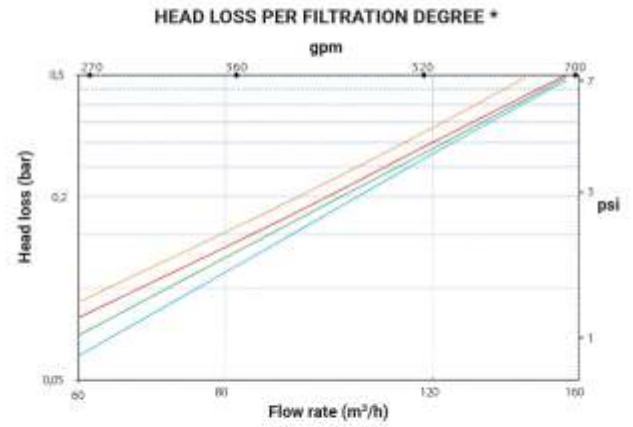
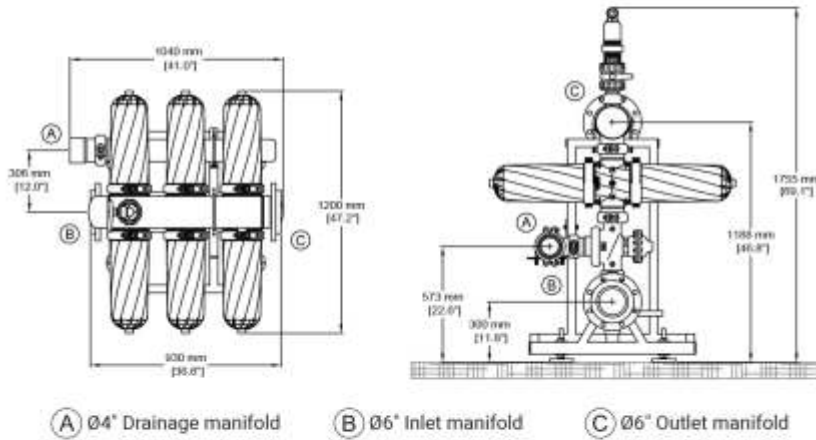

FT4DCL4 SW DLP

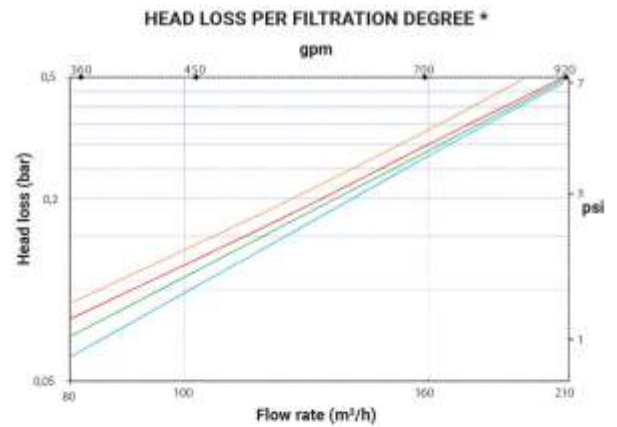
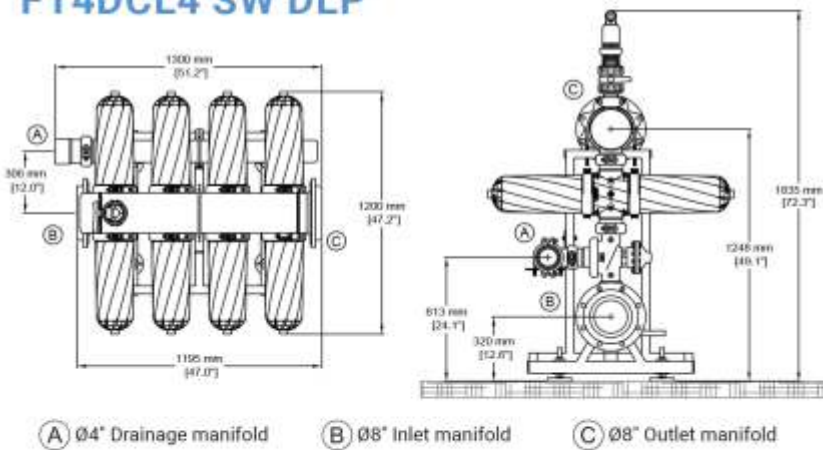

FT4DCL5 SW DLP

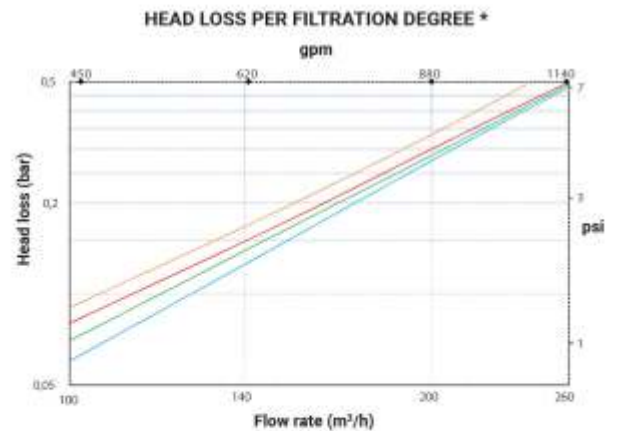
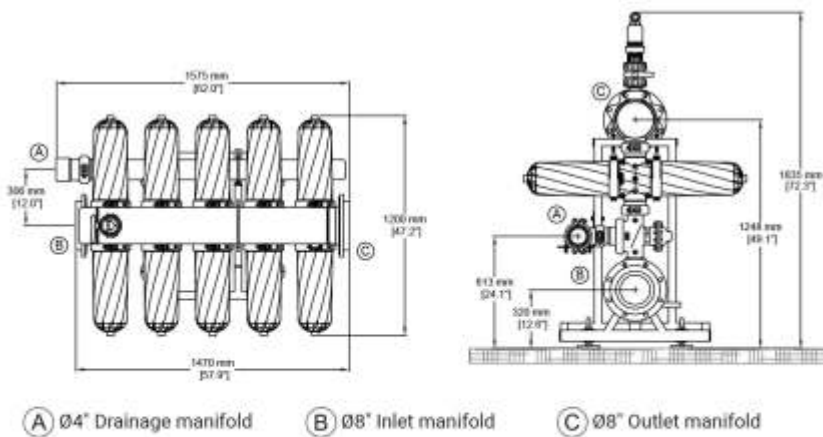

*The backwash frequency depends on the design flowrate. For hydraulic calculation, consider the set-point value for the self-cleaning cycle (usually 0.5 bar/7.25 psi).

MICRON 100 130 200 400

FT4DCL6 SW DLP

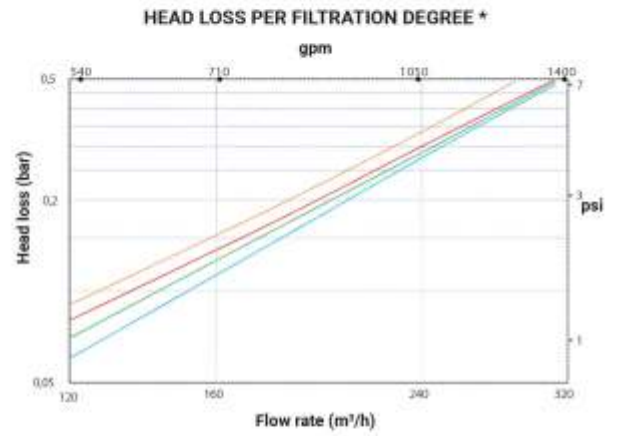
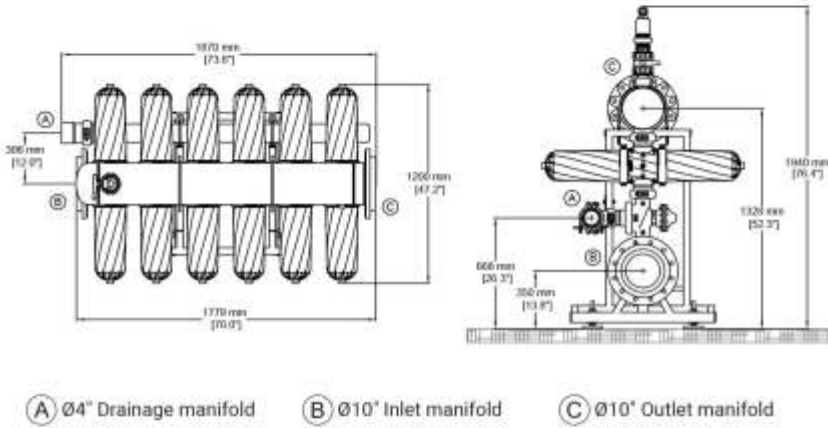

FT4DCL7 SW DLP

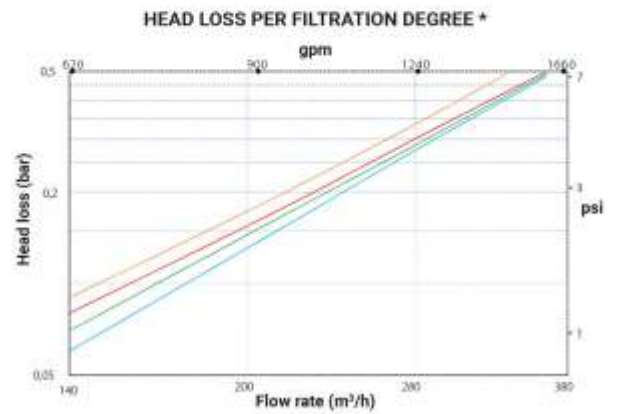
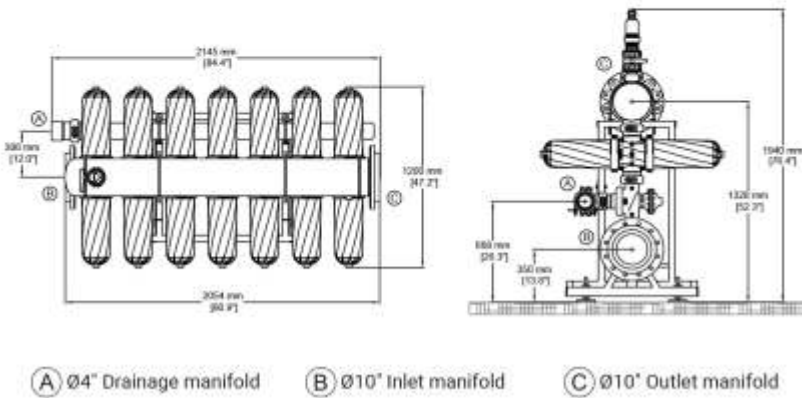

FT4DCL8 SW DLP

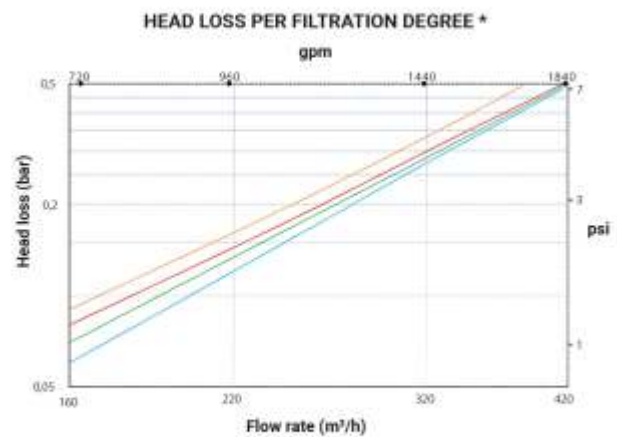
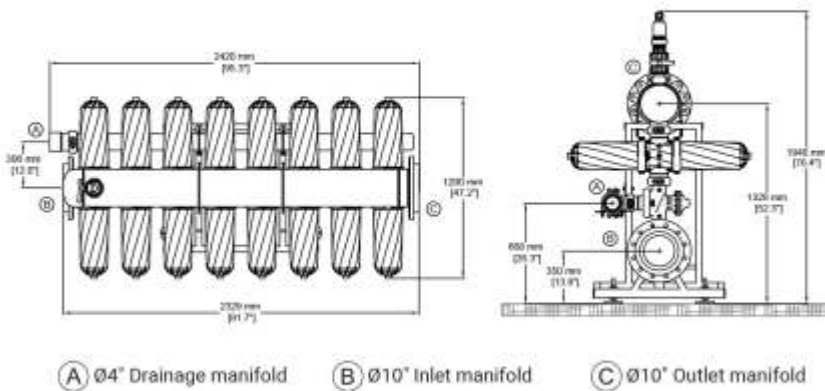

*The backwash frequency depends on the design flowrate. For hydraulic calculation, consider the set-point value for the self-cleaning cycle (usually 0.5 bar/7.25 psi).

MICRON 100 130 200 400

FT4DCL9 SW DLP

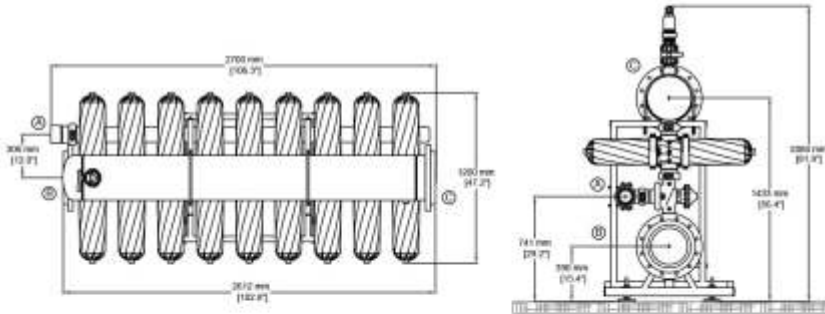

(A) Ø4" Drainage manifold (B) Ø12" Inlet manifold (C) Ø12" Outlet manifold

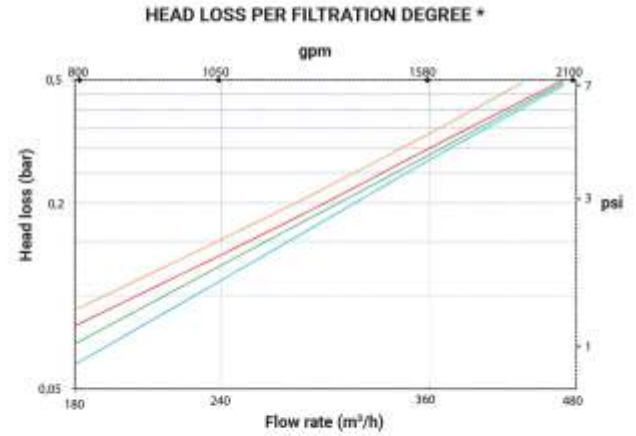

FT4DCL10 SW DLP

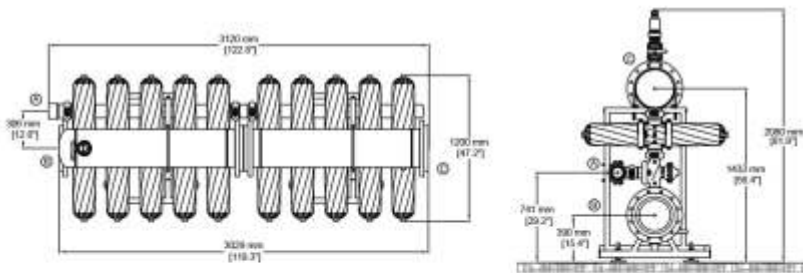

(A) Ø4" Drainage manifold (B) Ø12" Inlet manifold (C) Ø12" Outlet manifold

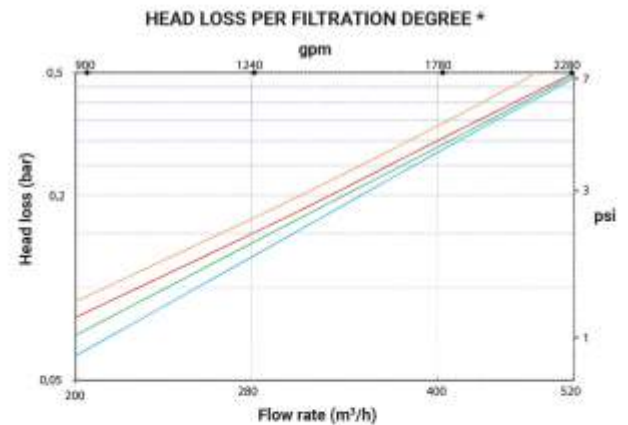

*The backwash frequency depends on the design flowrate. For hydraulic calculation, consider the set-point value for the self-cleaning cycle (usually 0.5 bar/7.25 psi).

! ASK FOR OUR EQUIPMENT UP TO 12 FILTERS



AZUD

WORLDWIDE



BELARUS



BRASIL



ARAB EMIRATES



MEXICO



QATAR



SOUTH AFRICA



CHINA



SOUTH KOREA



Geofluid Processors Private Limited

112, Building No.2, Mittal Industrial Estate,
Andheri Kurla Road, Marol, Andheri (E), Mumbai - 400 059.

+91-22- 6155 5888
info@geofluid.com

+91-22-6155 5800
www.geofluid.com