

SELF-CLEANING DISC FILTRATION EQUIPMENT

Working conditions

Salinity	6000 – 55000 mg/l
Max. working pressure	10 bar (145 psi)
Min. working pressure	0.8 bar (11.6 psi)
Min. backwash pressure	1.5 bar (22 psi)
Min. backwash flow	2.5 l/s (39 gpm) per filter
Backwash duration	15 - 25 s per filter
pH	4 - 11
Water temperature	≤ 60 °C (140 °F)

Filtration degrees (micron)

400	200	130	100	50	20	10	5
-----	-----	-----	-----	----	----	----	---

DLP Technology
Low Pressure Backflush



DESCRIPTION

Self-cleaning disc filtration equipment composed by 2 to 12 filters AZUD HELIX AUTOMATIC Ø2" with discs AZUD MG/WS, which perform an in-depth 3D filtration, installed in-line on Ø2"-10" inlet/outlet manifolds. Includes Ø2" backwash valves 3-way membrane type and the innovative DLP TECHNOLOGY, that enable the sequential low-pressure backwashing of each filter using filtered water from the rest of filters of the equipment, while continues the filtered water supply downstream. The patented AZUD HELIX anti-clogging deflector provides a reliable filtration thanks to an effect of centrifugal separation, with less backwash frequency and less water and energy consumption. The materials of construction of these equipment are specifically designed to optimize the filtration in installations with high salinity water.

Smart, compact and modular plug&play solution, increases the shelf life of the installation providing a long-term operation with minimum operational costs and less maintenance downtime.

APPLICATIONS



> Filtration in tanks, lakes and fountains



> Ultrafiltration membrane protection



> Make-up water filtration



> Media filters prefiltration

HOW DO THEY WORK

FILTRATION PHASE:

- Water flows from the inlet manifold to the inside of the filter, passing through the anti-clogging deflector AZUD HELIX, which throws the heavy particles away from the disc stack, avoiding the quick clogging of the filter and minimizing the backwash frequency.
- Water flows OUT-IN through the disc stack to the outlet manifold while particles bigger than the filtration degree are trapped in the discs.

SELF-CLEANING PHASE:

- When automatic backwash is activated, the pressurized water flows IN-OUT, decompressing the disc stack.
- High-speed flushing water flowing through the spray nozzles, creates a tangential cleaning effect that flush out the trapped particles.

▶ Check our YouTube channel for more details

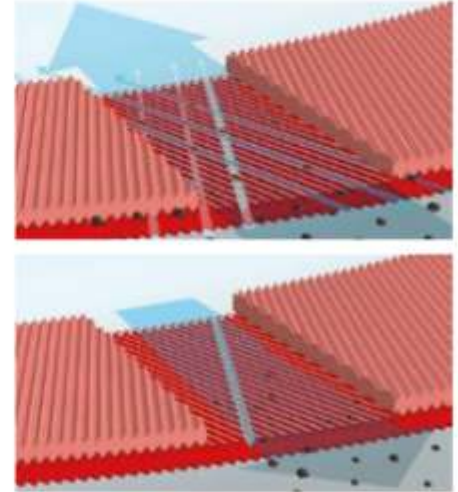

MODELS

Filtration area	Model	Q max. 50 µm* m³/h (gpm)	Q max. 130 µm* m³/h (gpm)	Connection	INLET AND OUTLET MANIFOLD			AZUD FBC control unit**
					DIN 2576	ANSI B16.5 CLASS 150	Grooved	
3240 cm²	FT202 SW 2 filters Ø2'	-	48 (211)	Ø3"	•	•	•	103/2 SW
4860 cm²	FT203 SW 3 filters Ø2'	42 (185)	50 (220) 72 (317)	Ø3" Ø4"	•	•	•	103/3 SW
6480 cm²	FT204 SW 4 filters Ø2'	56 (246)	80 (352) 96 (423)	Ø4" Ø6"	•	•	•	112/4 SW
8100 cm²	FT205 SW 5 filters Ø2'	70 (308)	80 (352) 120 (528)	Ø4" Ø6"	•	•	•	112/5 SW
9720 cm²	FT206 SW 6 filters Ø2'	84 (370)	144 (634)	Ø6"	•	•	•	112/6 SW
11340 cm²	FT207 SW 7 filters Ø2'	98 (431)	160 (705)	Ø6"	•	•	•	112/7 SW
12960 cm²	FT208 SW 8 filters Ø2'	112 (493)	160 (705) 192 (845)	Ø6" Ø8"	•	•	•	112/8 SW
14580 cm²	FT209 SW 9 filters Ø2'	126 (555)	160 (705) 216 (951)	Ø6" Ø8"	•	•	•	112/9 SW
16200 cm²	FT210 SW 10 filters Ø2'	140 (616)	160 (705) 240 (1057)	Ø6" Ø8"	•	•	•	112/10 SW
17820 cm²	FT211 SW 11 filters Ø2'	154 (678)	240 (1057) 264 (1162)	Ø8" Ø10"	•	•	•	112/11 SW
19440 cm²	FT212 SW 12 filters Ø2'	168 (740)	240 (1057) 288 (1268)	Ø8" Ø10"	•	•	•	112/12 SW

DRAINAGE MANIFOLD: Ø3" Grooved/PVC

*Maximum flowrate is limited by the size and type of the auxiliary elements (manifold, flanges and valves).

**AZUD FBC control unit not included with the equipment.

MATERIALS OF CONSTRUCTION

Filters	Backwash valves Inlet/outlet/drainage manifolds	Scheme
Filters Ø2" (2-12 units) <ul style="list-style-type: none"> • MG/WS discs: PP/HDPE • Support structure: rPP • Base-lid: rPA • Spring: HASTELLOY • Clamp: SS 316L • Sealing o-rings: NBR/HDPE 	Ø2" Valves 3 way-membrane (1 unit / filter) <ul style="list-style-type: none"> • Body: rPA • Axis, seat and spring: SS DUPLEX • Sealing o-rings: NBR • Command: Pneumatic (PN) Manifolds: HDPE PE-100 Flanges: PP coated steel	

PP: Polypropylene rPP: Reinforced polypropylene SS: Stainless steel rPA: Reinforced polyamide HDPE: High density polyethylene NBR: Nitrile rubber

FT202 SW DLP

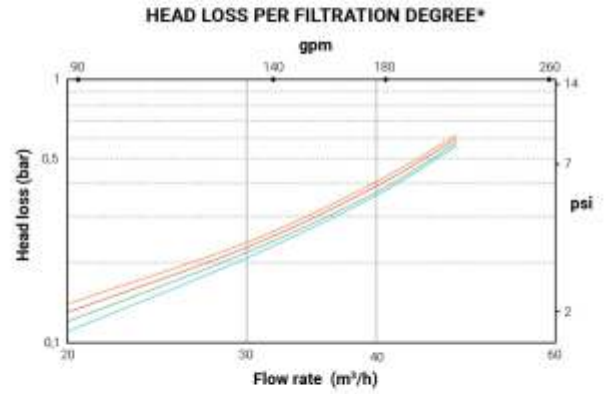
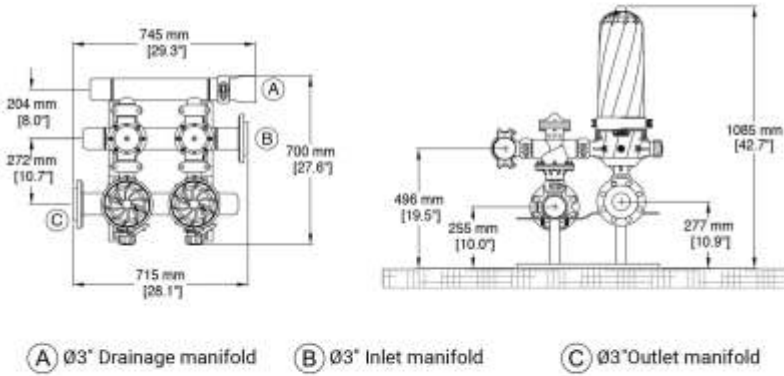

FT203 SW DLP

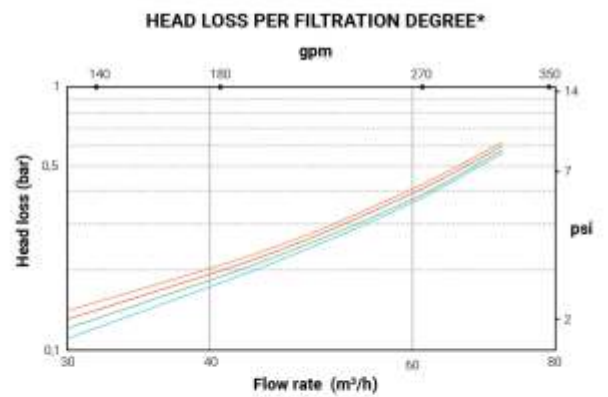
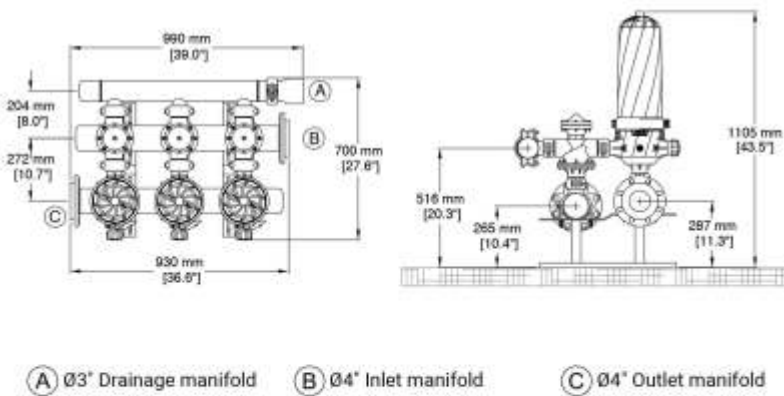

FT204 SW DLP

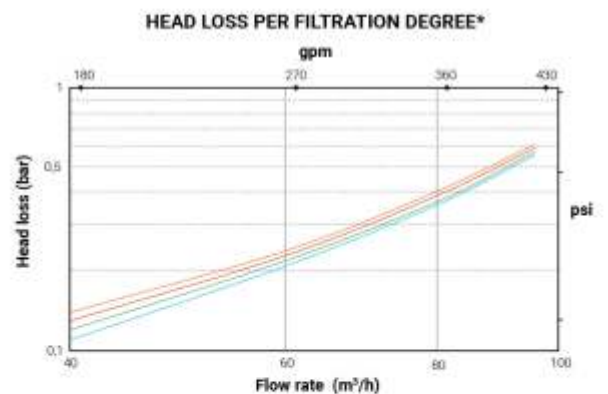
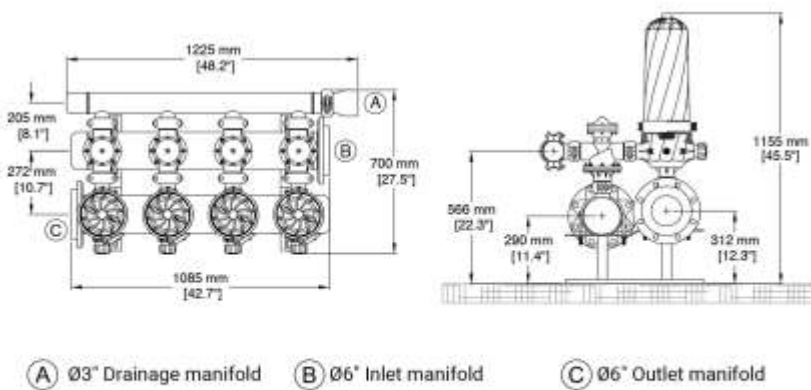

*The backwash frequency depends on the design flowrate. For hydraulic calculation, consider the set-point value for the self-cleaning cycle (usually 0.5 bar/7.25 psi).

FT205 SW DLP

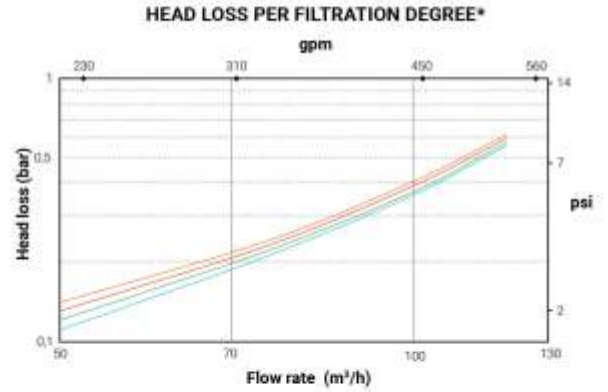
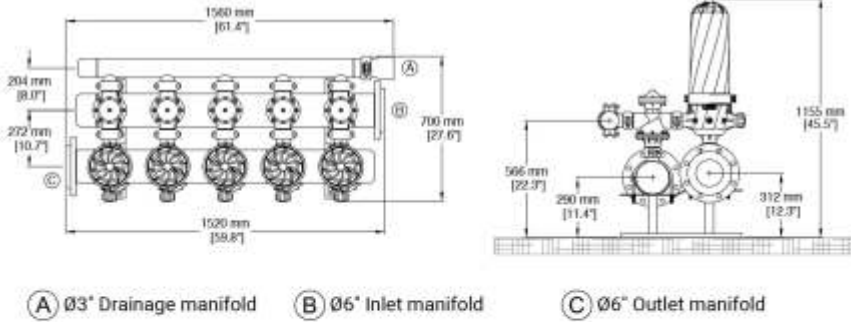

FT206 SW DLP

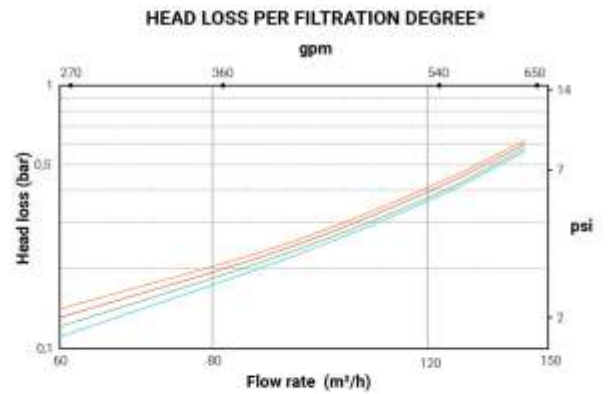
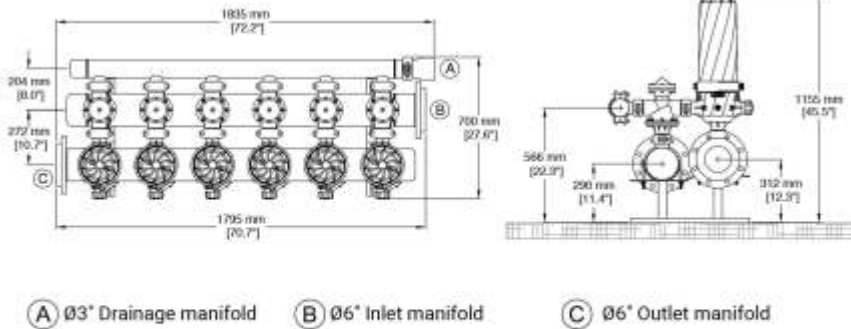

*The backwash frequency depends on the design flowrate. For hydraulic calculation, consider the set-point value for the self-cleaning cycle (usually 0.5 bar/7.25 psi).



AZUD

WORLDWIDE



BELARUS



BRASIL



ARAB EMIRATES



MEXICO



QATAR



SOUTH AFRICA



CHINA



SOUTH KOREA



Geofluid Processors Private Limited

112, Building No.2, Mittal Industrial Estate,
Andheri Kurla Road, Marol, Andheri (E), Mumbai - 400 059.

+91-22- 6155 5888
info@geofluid.com

+91-22-6155 5800
www.geofluid.com